



www.whiting.ca



Preferred Throughout the World.

Reliability is carefully engineered into every WHITING Portable Electric Jack. For over 80 years our outstanding design and top quality construction has provided years of dependable service with minimum maintenance. This tradition has established WHITING as the foremost manufacturer of portable electric jacks in the world.

Portable Electric Jacks

Whiting Equipment Canada Inc.

FEATURES



Screw & Nut

Butress Thread

- The load screw in each WHITING jack, is a machined butress thread.
- The butress thread has an inherent self locking feature which makes them ideal for lifting applications.
- No other manufacturer of jacks uses butress threads.

Screw In-Compression

- Our "screw in-compression" design eliminates possible breakage under load.
- The worst case failure scenario of a "screw in-compression" design is general wear of the threads.
- Other manufacturers differ by having their load screws in "tension".

Self- Locking

- WHITING's jacks are Self-Locking in case of power failure.

Synchronization

- WHITING's hoist duty jack motors are all designed and tested to be synchronized to each other as matched sets, to ensure that all jack screws are turning at the same speed.
- This eliminates the need for expensive equipment to continuously monitor any variation in turning speed and lifting height variations.

Electrical Components

- All electrical components are UL/CSA approved.

Motors

- WHITING jack motors are not an "off the shelf" item. They are specified as heavy duty Class D hoist motors. This ensures dependable and long term usage of the equipment.

Controls

- Each jack can be operated individually, or in sets.



Electrical Control

Lifting Brackets

- WHITING's lifting brackets are not required to be lowered to the shop floor to engage their portable wheel moving system.
- Lifting brackets can be modified to any configuration to suit the Customers lifting application.



Lifting Bracket



Call Whiting Equipment Canada Inc. for details at
905-732-7585 ext 256

STANDARD JACK DIMENSIONS (35 TON)

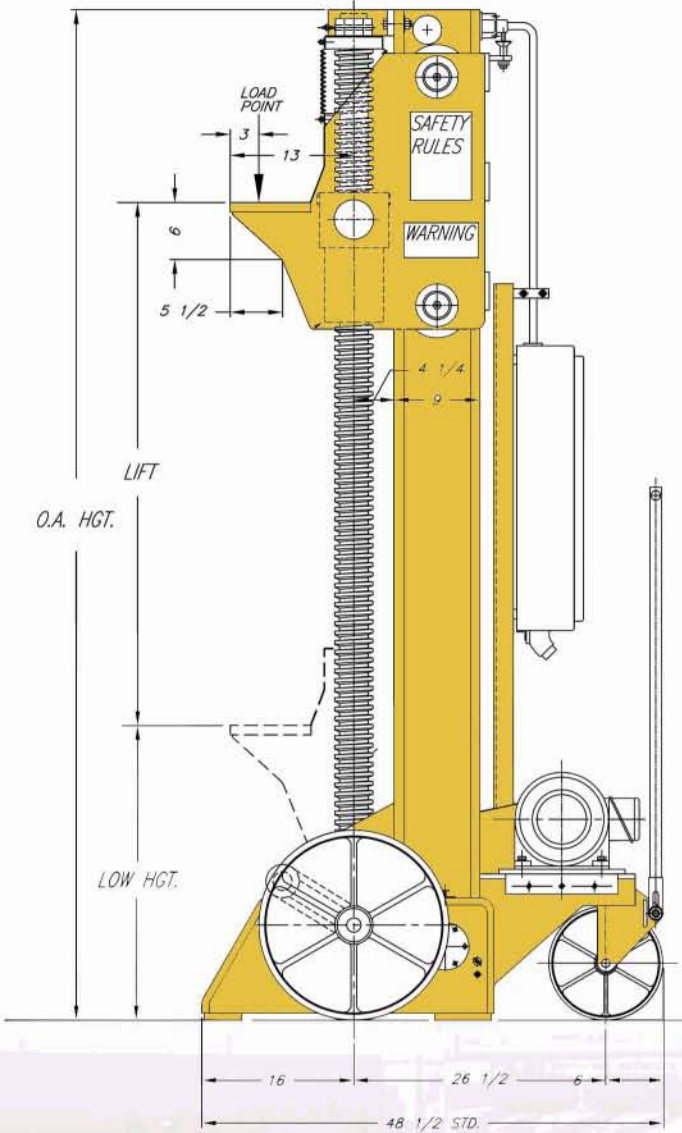

OPTIONAL LIFTING BRACKET DESIGNS

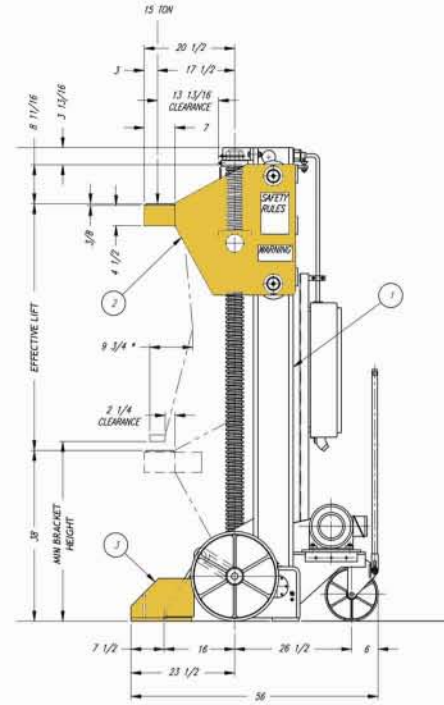

The lifting bracket on our jacks can be modified to suit any application and required clearances to a railcar vehicle body.

STANDARD JACK SPECIFICATIONS

MODEL	CAPACITY (metric ton)	HP (kw)	SPEED I.P.M. (mm/min)	EFFECTIVE LIFT (mm)	MINIMUM BRACKET HEIGHT (mm)	SCREW DIA (mm)	HEIGHT (mm)	WIDTH (mm)	LENGTH (mm)	WEIGHT (kg)
MA*	25 tons (22.5)	5 (3.73)	9"/min (229)	6' 0" (1828mm)	2' 7" (787)	3'15/16" (100)	10' 2-1/2" (3112)	3' 5-1/2" (1054)	4' 0-1/2" (1232)	2800 lbs (1270)
MA*	35 tons (31.5)	7.5 (5.59)	9"/min (229)	6' 0" (1828mm)	2' 7" (787)	3'15/16" (100)	10' 2-1/2" (3112)	3' 5-1/2" (1054)	4' 0-1/2" (1232)	2800 lbs (1270)
MB	50 tons (45)	12.5 (9.32)	8"/min (203)	6' 6" (1981mm)	2' 9" (838)	4'15/16" (125)	12' 1-7/8" (3731)	3' 5-1/2" (1054)	4' 5-7/8" (1368)	4700 lbs. (2132)
MC	60 tons (54)	15 (11.20)	8.5"/min (216)	5' 7" (1702mm)	2' 9" (838)	4'15/16" (125)	11' 6-7/8" (3528)	3' 5-1/2" (1054)	4' 6-3/8" (1381)	5000 lbs (2262)

*Please note that the 25 and 35 Ton jacks also come in a standard MAL Model with a minimum bracket height of 2'-3" (686mm) instead of 2'-7" (787mm).

OPTIONAL FEATURES

The following optional features are available for all models of WHITING Portable Electric Jack sets. They can be factory installed or can be purchased at a later date in kit form.

Zero Speed Shutdown System - AUTOMATICALLY SHUTS DOWN ALL THE JACKS IN A SET IF ONE JACK SCREW STOPS TURNING.

The addition of this feature will prevent a Jack Set from becoming unequally loaded or a vehicle tilted if any one of the jacks in the set stops due to a failure in the drive train.

Upper Overtravel Limit Switch - PREVENTS OVERTRAVEL OF THE LIFTING BRACKET IN THE EVENT OF FAILURE OF THE OPERATING UPPER LIMIT SWITCH.

The addition of this backup limit switch assembly provides a means for eliminating the danger of damage to a jack or a raised vehicle, should the operating "Upper Travel Limit Switch" malfunction at the top of the Lifting Bracket's allowable travel.

Nut Wear Indicator and Follower Nut - AUTOMATICALLY SHUTS DOWN ALL THE JACKS IN A SET IF ONE JACK NUT WEARS BEYOND ITS USABLE LIFE.

The addition of this dual purpose system allows unseen wear of Jack Nut threads to be monitored, visually, and electronically. The follower nut also serves as a safety back up.

Automatic Nut Lubricator - AUTOMATICALLY APPLIES SMALL AMOUNTS OF LUBRICANT TO THE LIFTING SCREWS AND NUTS.

The addition of this feature eliminates the problems of over and under greasing of lifting screws and nuts.

ADDITIONAL OFFERED SERVICES

Leasing and Renting - WHITING offers short term Renting and long term Leasing of our Jack Equipment. Call us for more details.

Inspection and Maintenance - WHITING offers yearly inspection and maintenance services on used Jack Equipment. Call us for more details.

Rebuilding- WHITING offers a complete teardown, full inspection and rebuilding service on any used Jack Equipment. Call us for more details.

